

# Chain Supply UK Sells Industrial Chain Products to suit any Application.

Chain Supply UK (CSUK) was founded in 2005 to source and supply all chain types & ancillary products for the industrial distribution market.

[chainsupply.co.uk](http://chainsupply.co.uk)



chainSupply<sup>UK</sup>



## Your Trusted Partner for Overcoming Industrial Chain Supply Challenges

In the world of industrial operations, the right chain can make or break your productivity. Chain Supply UK understands the unique challenges faced by buyers in this complex market, and we're here to provide the solutions you need to keep your operations running smoothly.



Mechanical & Electrical



Safety Solutions



Workplace Essentials

QUALITY | VALUE | SERVICE

## We ensure the Highest **QUALITY**, **VALUE** & **SERVICE** for all of our Customers

Your satisfaction is at the heart of everything we do. Our team of professionals is dedicated to understanding your unique needs, offering personalised solutions, and delivering products that meet and exceed your expectations. We take pride in fostering lasting relationships built on trust, reliability, and mutual success.



### Experience

With 25 years in the industry, we bring unparalleled expertise to the table.



### Value for Money

Competitive pricing without compromising on the excellence of our service.



### Product Quality

We meticulously source and supply products of the highest standards to meet your needs.



### Exceptional Service

Our commitment to your satisfaction drives our dedicated customer service.



SPECIALIST INDUSTRIAL CHAIN AND ANCILLARY PRODUCTS

# Core Product Range

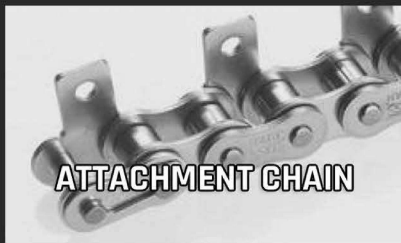

**Dedicated Account Managers:** Our experienced account managers provide personalized support throughout the entire process, from consultation to delivery.

## How CSUK solves typical Challenges for it's Customers:

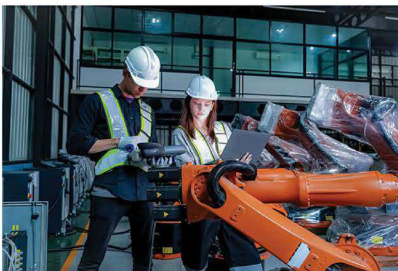

### Expert Consultation:

Our team of experienced engineers and chain specialists will work closely with you to understand your specific requirements and recommend the optimal chain solutions for your application.



### Unrivalled Selection:

We offer an extensive inventory of industrial chains, including roller chains, conveyor chains, leaf chains, and more. We partner with leading manufacturers to ensure consistent quality and reliable application.



### First Class Service:

Our efficient processes and strong supplier relationships guarantee timely delivery of your orders, no matter how complex application.

# CSUK quality Roller Chain is highly fatigue resistant, giving up to four times the life of other leading competitor chains

Applications of CSUK industrial chains are vast and diverse. The specific types of chains used by our customer base may vary depending on the industry and application, but BS roller chains are a popular choice due to their versatility and reliability.

## Chain Supply UK provide a complete procurement solution:



**One-Stop Shop:** We offer a vast inventory of MRO products, from bearings and power transmission components to lubricants, tools, and safety gear. Find everything you need in one place.



**Expert Guidance:** Our experienced team understands the unique needs of various industries and can help you select the right products for your specific applications.

**Reliable Supply Chain:** We maintain a robust supply chain with reliable partners, ensuring you have access to the products you need when you need them.



**Technical Support:** Our knowledgeable team is available to provide technical support, troubleshooting assistance, and product recommendations to ensure your operations run smoothly.

**Cost Savings:** By partnering with Howcroft Group, you can consolidate your MRO procurement, reduce administrative overhead, and utilise our product & industry knowledge, skills and experience to best effect.

**Quality Assurance:** We only source products from reputable manufacturers who meet our stringent quality standards, ensuring you get reliable, high-performance MRO products at a competitive cost.



**Inventory Management:** We offer inventory management services to help you track your stock levels, automate reordering, and optimize your inventory for maximum efficiency.

**Competitive Pricing:** We leverage our strong supplier relationships to negotiate the best possible prices for our customers, ensuring you get maximum value for your investment.



SPECIALIST INDUSTRIAL CHAIN AND ANCILLARY PRODUCTS

# Industry Sectors Served

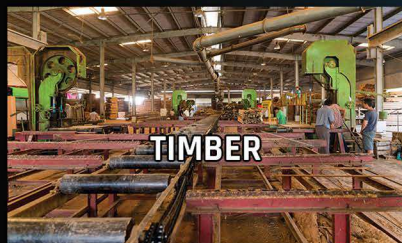
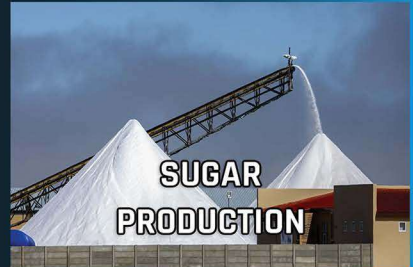



# In the world of industrial operations, the right chain can make or break your productivity.

Chain Supply UK understands the unique challenges faced by buyers in this complex market, and we're here to provide the solutions you need to keep your operations running smoothly.

## Common Challenges Faced by Industrial Chain Buyers:



With so many types, sizes, and materials available, finding the perfect chain for your specific application can be daunting. Incorrect selection can lead to premature wear, breakdowns, and costly downtime.



Not all chain suppliers are created equal. Quality issues, inconsistent stock, and unreliable delivery times can wreak havoc on your production schedule.



Coordinating orders for multiple chain types and sizes, ensuring timely delivery, and dealing with unexpected issues can be a logistical nightmare.



When problems arise, having access to knowledgeable technical support is essential to quickly diagnose and resolve issues.



# ANSI Heavy Series Roller Chain

## Technical Data Sheet

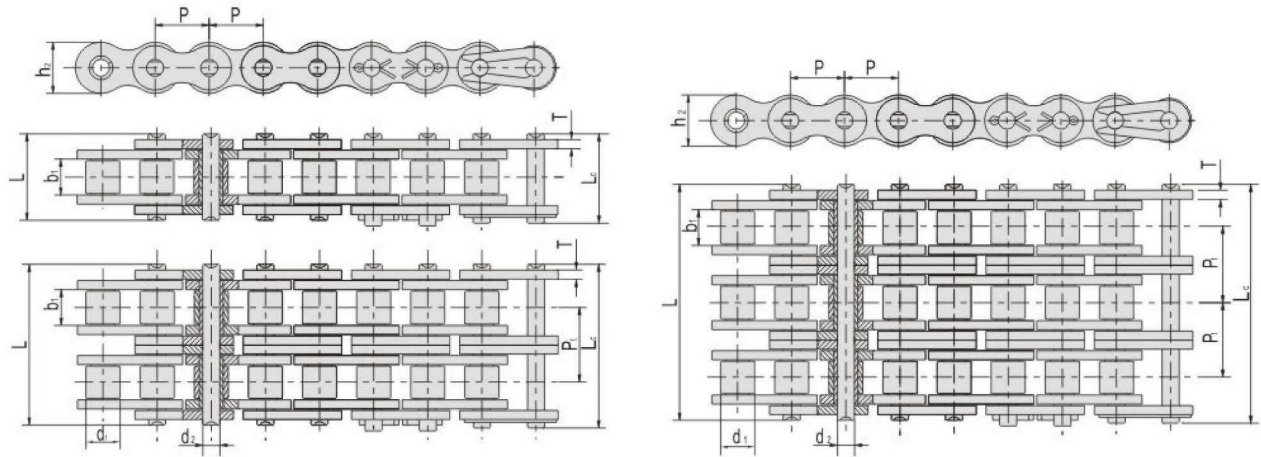

ISO 链号	ANSI 链号	节距 Pitch	滚子直径 Roller diameter	内节内宽 Width between inner plates	销轴直径 Pin diameter	销轴长度 Pin length		内链板高度 Inner plate depth	链板厚度 Plate thickness	排距 Transverse pitch	极限拉伸载荷 Ultimate tensile strength	平均拉伸载荷 Average tensile strength	每米长重 Weight per meter
						L max	L <sub>c</sub> max						
ISO Chain No.	ANSI Chain No.	P	d <sub>1</sub> max	b <sub>1</sub> min	d <sub>2</sub> max	L max	L <sub>c</sub> max	h <sub>2</sub> max	T max	Pt	Q min	Q <sub>o</sub>	q
		mm	mm	mm	mm	mm	mm	mm	mm	mm	KN	KN	kg/m
	*35H	9.525	5.08	4.68	3.58	13.3	14.3	9.0	1.5		7.9	10.8	0.14
08AH-1	40H	12.70	7.92	7.85	3.96	18.8	19.9	12.00	2.03		14.1	19.1	0.82
10AH-1	50H	15.875	10.16	9.40	5.08	22.1	23.4	15.09	2.42		22.2	30.2	1.25
12AH-1	60H	19.05	11.91	12.57	5.94	29.3	31.0	18.00	3.25		31.8	42.7	1.87
16AH-1	80H	25.40	15.88	15.75	7.92	36.2	37.7	24.00	4.00		56.7	71.4	3.10
20AH-1	100H	31.75	19.05	18.90	9.53	43.6	46.9	30.00	4.80		88.5	112.4	4.52
24AH-1	120H	38.10	22.23	25.22	11.10	53.5	57.5	35.70	5.60		127.0	160.9	6.60
28AH-1	140H	44.45	25.40	25.22	12.70	57.6	62.2	41.00	6.40		172.4	217.3	8.30
32AH-1	160H	50.80	28.58	31.55	14.27	68.2	73.0	47.80	7.20		226.8	285.8	11.10
40AH-1	200H	63.50	39.68	37.85	19.85	86.6	93.5	60.00	9.50		353.8	444.5	19.16
12AH-2	60H-2	19.05	11.91	12.57	5.94	55.3	57.1	18.00	3.25	26.11	63.6	84.5	3.71
16AH-2	80H-2	25.40	15.88	15.75	7.92	68.8	70.3	24.00	4.00	32.59	113.4	145.3	6.15
20AH-2	100H-2	31.75	19.05	18.90	9.53	82.7	86.0	30.00	4.80	39.09	177.0	225.9	9.03
24AH-2	120H-2	38.10	22.23	25.22	11.10	102.4	106.4	35.70	5.60	48.87	254.0	322.7	13.13
28AH-2	140H-2	44.45	25.40	25.22	12.70	109.8	114.4	41.00	6.40	52.20	344.8	437.7	16.60
32AH-2	160H-2	50.80	28.58	31.55	14.27	130.1	134.9	47.80	7.20	61.90	453.6	571.6	22.06
40AH-2	200H-2	63.50	39.68	37.85	19.85	164.9	171.8	60.00	9.50	78.31	707.6	894.9	38.11
12AH-3	60H-3	19.05	11.91	12.57	5.94	81.4	83.2	18.00	3.25	26.11	95.4	113.9	5.54
16AH-3	80H-3	25.40	15.88	15.75	7.92	101.4	102.9	24.00	4.00	32.59	170.1	203.5	9.42
20AH-3	100H-3	31.75	19.05	18.90	9.53	121.8	125.1	30.00	4.80	39.09	265.5	314.8	12.96
24AH-3	120H-3	38.10	22.23	25.22	11.10	151.2	155.2	35.70	5.60	48.87	381.0	444.7	19.64
28AH-3	140H-3	44.45	25.40	25.22	12.70	162.0	166.6	41.00	6.40	52.20	517.2	598.4	24.90
32AH-3	160H-3	50.80	28.58	31.55	14.27	192.0	196.8	47.80	7.20	61.90	680.4	787.3	30.10
40AH-3	200H-3	63.50	39.68	37.85	19.85	243.2	250.1	60.00	9.50	78.31	1061.4	1228.2	57.06

# ANSI Roller Chain

## Technical Data Sheet

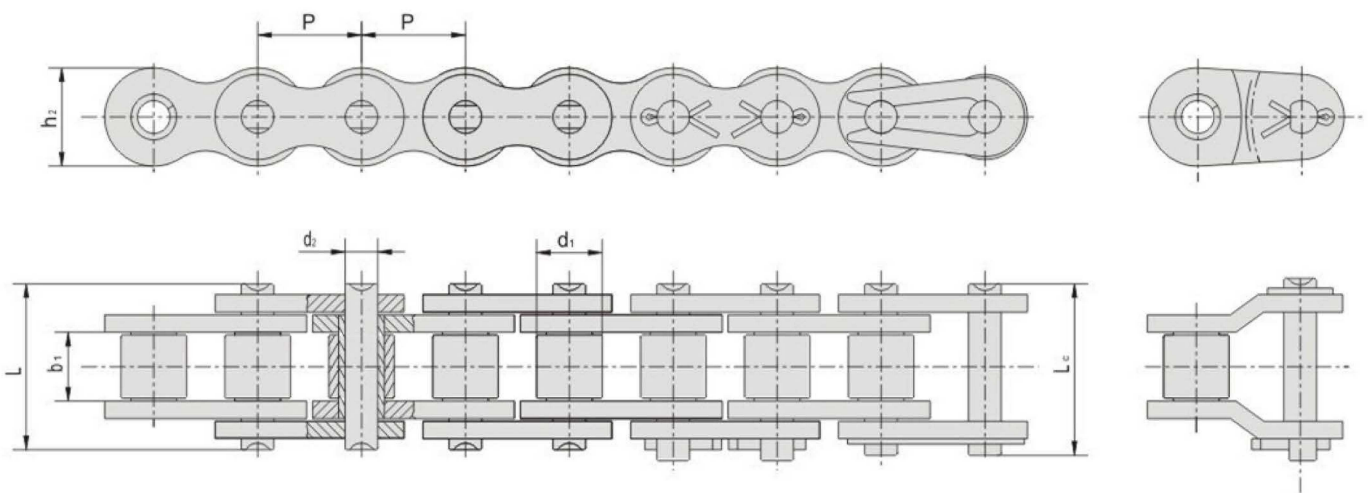

DIN/ISO 链号	ANSI 链号	节距 Pitch	滚子直径 Roller diameter	内节内宽 Width between inner plates	销轴直径 Pin diameter	销轴长度 Pin length		内链板高度 Inner plate depth	排距 Transverse pitch	极限拉伸载荷 Ultimate tensile strength	平均拉伸载荷 Average tensile strength	每米长重 Weight per meter
DIN/ISO Chain No.	ANSI Chain No.	P	d <sub>2</sub> max	b <sub>1</sub> min	d <sub>1</sub> max	L max	L <sub>c</sub> max	h <sub>c</sub> max	pt	Q min	Q <sub>o</sub>	q
		mm	mm	mm	mm	mm	mm	mm	mm	KN	KN	kg/m
	*10	3.175	1.7	1.6	1.16	4.45	/	2.90	/	1.2	1.30	0.039
	*15	4.7625	2.48	2.4	1.62	6.25	/	4.30	/	1.8	2.00	0.089
04C-1	*25	6.35	3.30	3.10	2.31	7.80	8.90	5.90	/	3.5	4.60	0.15
06C-1	*35	9.525	5.08	4.77	3.58	12.15	13.10	8.70	/	7.9	10.80	0.34
085-1	41	12.70	7.77	6.25	3.58	13.75	15.00	9.91	/	6.8	12.60	0.45
08A-1	40	12.70	7.92	7.85	3.96	16.60	17.75	12.00	/	14.1	17.50	0.66
10A-1	50	15.875	10.16	9.40	5.08	20.60	22.00	15.00	/	22.2	29.40	1.08
12A-1	60	19.05	11.91	12.57	5.94	25.90	27.50	18.00	/	31.8	41.50	1.59
16A-1	80	25.40	15.88	15.75	7.92	32.80	34.90	24.00	/	56.7	69.40	2.73
20A-1	100	31.75	19.05	18.90	9.53	40.00	43.40	30.10	/	88.5	109.20	3.99
24A-1	120	38.10	22.23	25.22	11.10	50.45	53.50	36.10	/	127.0	156.30	5.62
28A-1	140	44.45	25.40	25.22	12.70	54.40	58.70	42.10	/	172.4	212.00	7.95
32A-1	160	50.80	28.58	31.55	14.27	64.50	68.70	48.10	/	226.8	278.90	10.1
36A-1	180	57.15	35.71	35.48	17.46	72.80	78.60	53.60	/	280.2	341.80	13.59
40A-1	200	63.50	39.68	37.85	19.84	79.50	85.50	60.00	/	353.8	431.60	16.86
48A-1	240	76.2	47.63	47.4	23.81	95.50	102.50	71.80	/	510.3	622.50	24.4



# ANSI Stainless Steel Roller Chain

## Technical Data Sheet

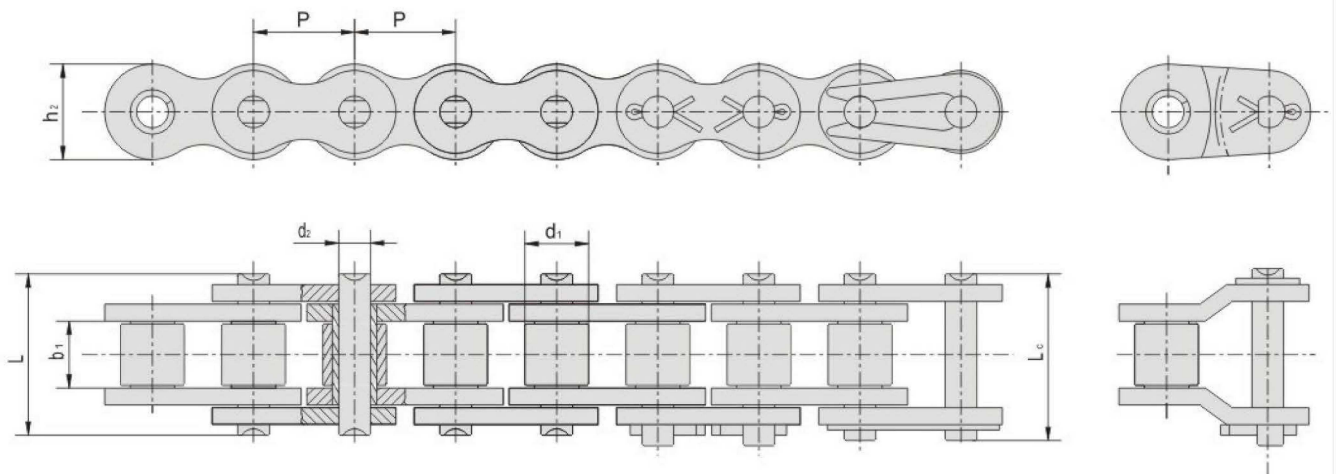

永利百合 链号  UNIBear Chain No.	节距	滚子直径	内节内宽	销轴直径	销轴长度		内链板高度	极限拉伸载荷	平均拉伸载荷	每米长重
	Pitch	Roller diameter	Width Between inner plates	Pin diameter	L max	Lc max	Inner plate depth	Ultimate tensile strength	Average tensile strength	Weight per meter
	P	d1 max	b1 min	d2 max	L max	Lc max	h2 max	Q min	Q0	q
	mm	mm	mm	mm	mm	mm	mm	kN	kN	kg/m
25SS	6.35	3.30	3.10	2.31	7.8	8.45	5.9	2.34	2.5	0.14
35SS	9.525	5.08	4.68	3.58	12.15	13.1	9.0	5.1	7.5	0.35
40SS	12.7	7.92	7.85	3.96	16.6	17.75	12.0	10.2	12.1	0.65
50SS	15.875	10.16	9.40	5.08	20.9	22.2	15.09	16.2	21.2	1.04
60SS	19.05	11.91	12.57	5.94	25.9	27.5	18.0	23.6	25.6	1.55
80SS	25.4	15.88	15.75	7.92	32.8	34.9	24.0	41.0	48.7	2.63
100SS	31.75	19.05	18.90	9.53	40.0	43.4	30.1	59.4	62.3	3.99
120SS	38.1	22.23	25.22	11.1	50.45	53.5	36.1	92.8	97.3	5.87
05BSS	8.0	5.00	3.00	2.31	8.0	8.9	7.11	3.3	4.2	0.182
06BSS	9.525	6.35	5.72	3.28	13.2	14.2	8.2	4.5	5.7	0.381
08BSS	12.7	8.51	7.76	4.45	16.7	18.0	11.8	10.0	12.2	0.737
10BSS	15.875	10.16	9.65	5.08	19.6	21.0	14.7	14.0	16.2	0.949
12BSS	19.05	12.07	11.68	5.72	22.5	24.0	16.1	15.3	17.7	1.216
16BSS	25.4	15.88	17.02	8.28	36	37.2	21.05	40.6	46.7	2.767
20BSS	31.75	19.05	19.56	10.19	41.1	44.7	26.3	56.0	64.3	3.68

# ANSI Straight Side Plate Roller Chain

## Technical Data Sheet

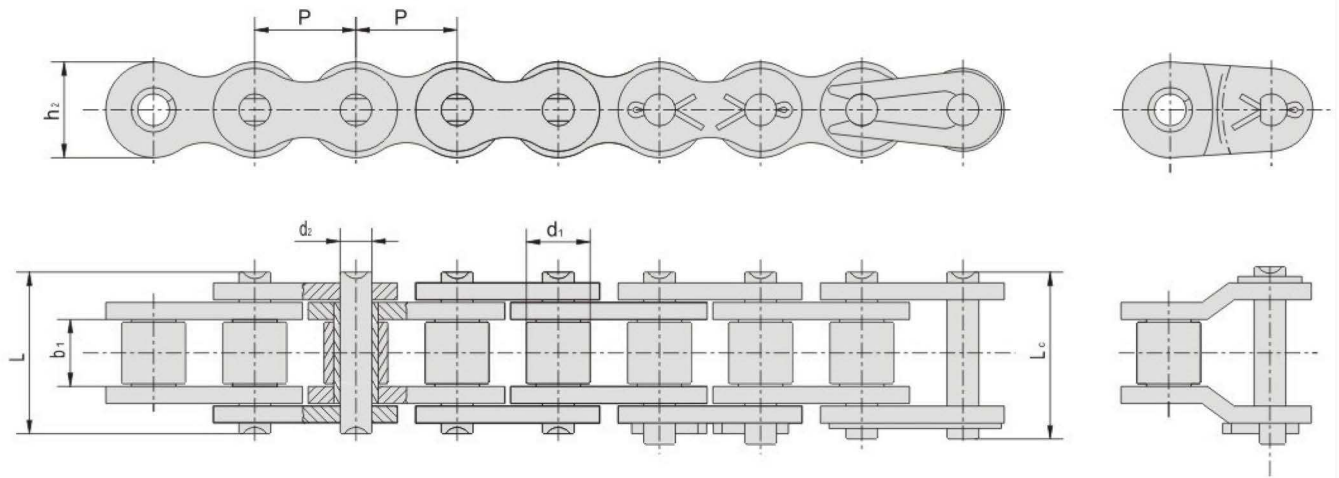

永利百合 链号  UNIBear Chain No.	节距	滚子直径	内节内宽	销轴直径	销轴长度		内链板高度	极限拉伸载荷	平均拉伸载荷	每米长重
	Pitch	Roller diameter	Width Between inner plates	Pin diameter	Pin length		Inner plate depth	Ultimate tensile strength	Average tensile strength	Weight per meter
	P	d1 max	b1 min	d2 max	L max	Lc max	h2 max	Q min	Q0	q
	mm	mm	mm	mm	mm	mm	mm	kN	kN	kg/m
25SS	6.35	3.30	3.10	2.31	7.8	8.45	5.9	2.34	2.5	0.14
35SS	9.525	5.08	4.68	3.58	12.15	13.1	9.0	5.1	7.5	0.35
40SS	12.7	7.92	7.85	3.96	16.6	17.75	12.0	10.2	12.1	0.65
50SS	15.875	10.16	9.40	5.08	20.9	22.2	15.09	16.2	21.2	1.04
60SS	19.05	11.91	12.57	5.94	25.9	27.5	18.0	23.6	25.6	1.55
80SS	25.4	15.88	15.75	7.92	32.8	34.9	24.0	41.0	48.7	2.63
100SS	31.75	19.05	18.90	9.53	40.0	43.4	30.1	59.4	62.3	3.99
120SS	38.1	22.23	25.22	11.1	50.45	53.5	36.1	92.8	97.3	5.87
05BSS	8.0	5.00	3.00	2.31	8.0	8.9	7.11	3.3	4.2	0.182
06BSS	9.525	6.35	5.72	3.28	13.2	14.2	8.2	4.5	5.7	0.381
08BSS	12.7	8.51	7.76	4.45	16.7	18.0	11.8	10.0	12.2	0.737
10BSS	15.875	10.16	9.65	5.08	19.6	21.0	14.7	14.0	16.2	0.949
12BSS	19.05	12.07	11.68	5.72	22.5	24.0	16.1	15.3	17.7	1.216
16BSS	25.4	15.88	17.02	8.28	36	37.2	21.05	40.6	46.7	2.767
20BSS	31.75	19.05	19.56	10.19	41.1	44.7	26.3	56.0	64.3	3.68



# BS Roller Chain

## Technical Data Sheet

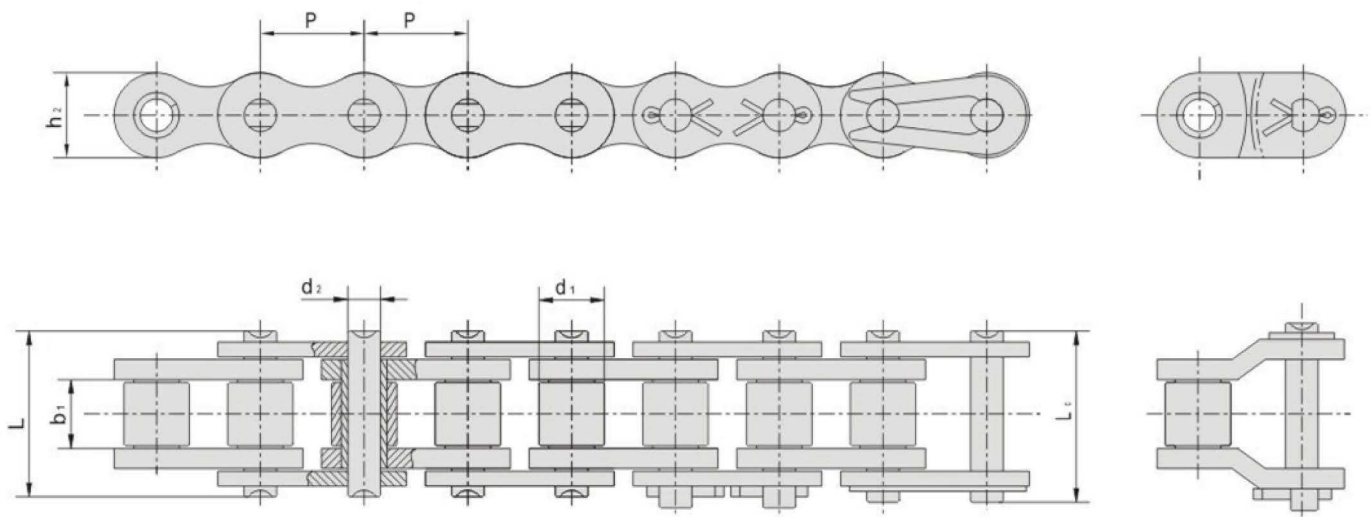

DIN/ISO 链号	节距 Pitch	滚子直径 Roller diameter	内节内宽 Width between inner plates	销轴直径 Pin diameter	销轴长度 Pin length		内链板高度 Inner plate depth	排距 Transverse pitch	极限拉伸载荷 Ultimate tensile strength	平均拉伸载荷 Average tensile strength	每米长重 Weight per meter
DIN/ISO Chain No.	P	d <sub>1</sub> max	b <sub>1</sub> min	d <sub>2</sub> max	L max	L <sub>c</sub> max	h <sub>c</sub> max	pt	Q min	Q <sub>o</sub>	q
	mm	mm	mm	mm	mm	mm	mm	mm	KN	KN	kg/m
04B-1	6.0	4.00	2.80	1.85	6.80	7.1	5.00	/	3.0	3.2	0.12
05B-1	8.0	5.00	3.00	2.31	8.00	8.9	7.00	/	5.0	5.9	0.19
06B-1	9.525	6.35	5.72	3.28	13.20	14.2	8.20	/	9.0	10.4	0.42
08B-1	12.70	8.51	7.75	4.45	16.50	18.0	11.80	/	18.0	19.4	0.71
10B-1	15.875	10.16	9.65	5.08	19.60	21.0	14.70	/	22.4	27.5	0.95
12B-1	19.05	12.07	11.68	5.72	22.50	24.0	16.10	/	29.0	32.2	1.24
16B-1	25.40	15.88	17.02	8.28	35.60	37.2	21.00	/	60.0	72.8	2.84
20B-1	31.75	19.05	19.56	10.19	40.80	44.2	26.30	/	95.0	106.7	4.04
24B-1	38.10	25.40	25.40	14.63	53.30	58.0	33.30	/	160.0	178.0	7.14
28B-1	44.45	27.94	30.99	15.90	65.00	70.3	36.80	/	200.0	222.0	9.48
32B-1	50.80	29.21	30.99	17.81	65.20	71.0	42.00	/	250.0	227.5	10.19
40B-1	63.50	39.37	38.10	22.89	82.20	89.2	52.96	/	355.0	394.0	16.2
48B-1	76.20	48.26	45.72	29.24	99.10	107.00	63.80	/	560.0	621.6	25.52
56B-1	88.90	53.98	53.34	34.32	114.60	123.00	77.80	/	850.0	940.0	35.53
64B-1	101.60	63.50	60.96	39.40	130.30	140.00	89.67	/	1120.0	1240	45.77
72B-1	114.30	72.39	68.58	44.48	147.00	156.00	103.60	/	1400.0	1550	60.5

# ANSI Straight Side Plate Roller Chain

## Technical Data Sheet

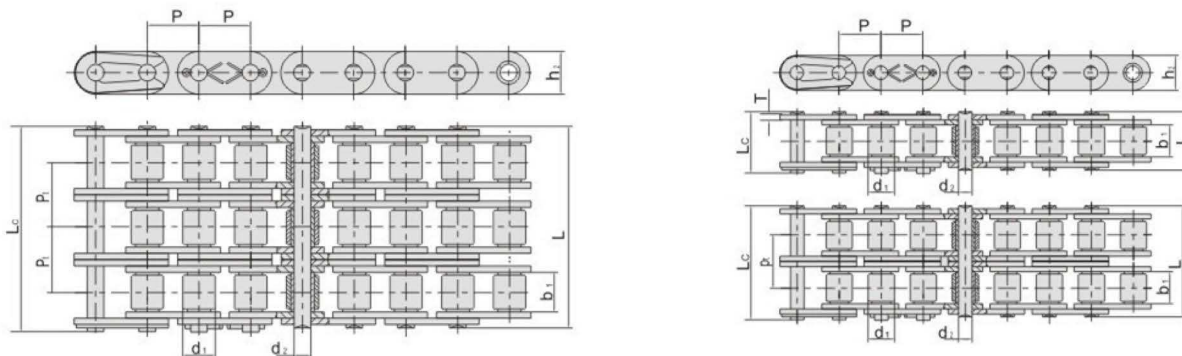

SIO 链号	ANSI 链号	节距 Pitch	滚子直径 Roller diameter	内节内宽 Width between inner plates	销轴长度 Pin length		销轴直径 Pin diameter	内链板高度 Inner plate depth	链板厚度 Plate thick- ness	排距 Transverse pitch	极限拉伸载荷 Ultimate tensile strength	平均拉伸载荷 Average tensile strength	每米长重 Weight per meter
					L	L <sub>c</sub>							
					max	max							
SIO Chain No.	ANSI Chain No.	P	d <sub>1</sub> max	b <sub>1</sub> min	L max	L <sub>c</sub> max	d <sub>2</sub> max	h <sub>2</sub> max	T	Pt	Q min	Q <sub>o</sub>	q
		mm	mm	mm	mm	mm	mm	mm	mm	mm	KN	KN	kg/m
	*C35	9.525	5.08	4.68	12.15	13.1	3.58	9.0	1.30		7.9	10.8	0.41
C08A-1	C40	12.70	7.92	7.85	16.60	17.75	3.96	12.00	1.50		14.1	17.5	0.73
C10A-1	C50	15.875	10.16	9.40	20.90	22.2	5.08	15.09	2.03		22.2	29.4	1.23
C12A-1	C60	19.05	11.91	12.57	25.90	27.5	5.94	18.00	2.42		31.8	41.5	1.81
C16A-1	C80	25.40	15.88	15.75	32.80	34.90	7.92	24.00	3.25		56.7	69.4	3.09
C20A-1	C100	31.75	19.05	18.90	40.00	43.40	9.53	30.10	4.00		88.5	109.2	4.56
C24A-1	C120	38.10	22.23	25.22	50.45	53.50	11.10	36.10	4.80		127.0	156.3	6.86
C28A-1	C140	44.45	25.40	25.22	54.40	59.00	12.70	42.10	5.60		172.4	212.0	8.49
C32A-1	C160	50.80	28.58	31.55	64.50	68.70	14.27	48.10	6.40		226.8	276.9	11.50
C08A-2	C40-2	12.70	7.92	7.85	31.10	32.25	3.96	12.00	1.50	14.38	28.2	35.9	1.43
C10A-2	C50-2	15.875	10.16	9.40	39.00	40.30	5.08	15.09	2.03	18.11	44.4	58.1	2.42
C12A-2	C60-2	19.05	11.91	12.57	48.80	50.30	5.94	18.00	2.42	22.78	63.6	82.1	3.58
C16A-2	C80-2	25.40	15.88	15.75	62.70	64.20	7.92	24.00	3.25	29.29	113.4	141.8	6.12
C20A-2	C100-2	31.75	19.05	18.90	76.20	80.50	9.53	30.10	4.00	35.76	177.0	219.4	9.08
C24A-2	C120-2	38.10	22.23	25.22	95.80	99.70	11.10	36.10	4.80	45.44	254.0	314.9	13.60
C28A-2	C140-2	44.45	25.40	25.22	103.30	107.90	12.70	42.10	5.60	48.87	344.8	427.5	16.86
C32A-2	C160-2	50.80	28.58	31.55	123.30	128.10	14.27	48.10	6.40	58.55	453.6	562.4	22.90
C08A-3	C40-3	12.70	7.92	7.85	45.60	47.00	3.96	12.00	1.50	14.38	42.3	50.0	2.14
C10A-3	C50-3	15.875	10.16	9.40	57.40	59.10	5.08	15.09	2.03	18.11	66.6	77.8	3.62
C12A-3	C60-3	19.05	11.91	12.57	71.50	73.20	5.94	18.00	2.42	22.78	95.4	111.1	5.36
C16A-3	C80-3	25.40	15.88	15.75	91.70	93.50	7.94	24.00	3.25	29.29	170.1	198.4	9.10
C20A-3	C100-3	31.75	19.05	18.90	112.20	116.30	9.53	30.10	4.00	35.76	265.5	309.6	13.60
C24A-3	C120-3	38.10	22.23	25.22	141.40	145.20	11.10	36.10	4.80	45.44	381.0	437.2	20.43
C28A-3	C140-3	44.45	25.40	25.22	151.8	156.80	12.70	42.10	5.60	48.47	517.2	593.3	25.23
C32A-3	C160-3	50.80	28.58	31.55	181.8	186.60	14.27	48.10	6.40	58.55	680.4	780.6	34.19



# BS Straight Side Plate Chain

## Technical Data Sheet

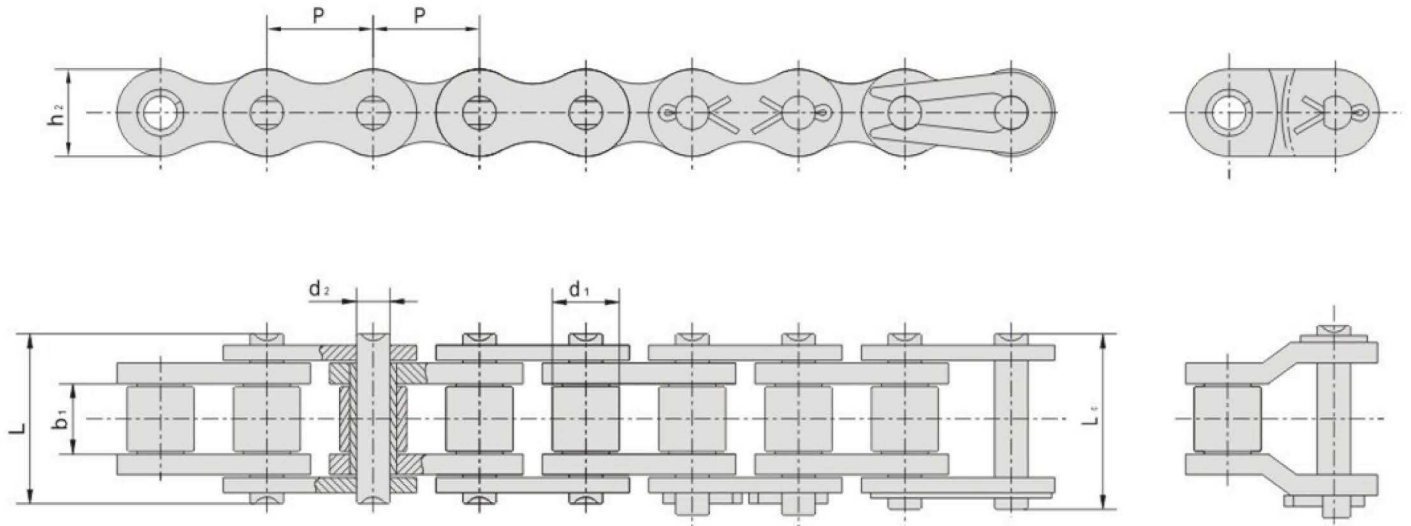

DIN/ISO 链号	节距 Pitch	滚子直径 Roller diameter	内节内宽 Width between inner plates	销轴直径 Pin diameter	销轴长度 Pin length		内链板高度 Inner plate depth	排距 Transverse pitch	极限拉伸载荷 Ultimate tensile strength	平均拉伸载荷 Average tensile strength	每米长重 Weight per meter
DIN/ISO Chain No.	P	d <sub>1</sub> max	b <sub>1</sub> min	d <sub>2</sub> max	L max	L <sub>c</sub> max	h <sub>c</sub> max	pt	Q min	Q <sub>o</sub>	q
	mm	mm	mm	mm	mm	mm	mm	mm	KN	KN	kg/m
04B-1	6.0	4.00	2.80	1.85	6.80	7.1	5.00	/	3.0	3.2	0.12
05B-1	8.0	5.00	3.00	2.31	8.00	8.9	7.00	/	5.0	5.9	0.19
06B-1	9.525	6.35	5.72	3.28	13.20	14.2	8.20	/	9.0	10.4	0.42
08B-1	12.70	8.51	7.75	4.45	16.50	18.0	11.80	/	18.0	19.4	0.71
10B-1	15.875	10.16	9.65	5.08	19.60	21.0	14.70	/	22.4	27.5	0.95
12B-1	19.05	12.07	11.68	5.72	22.50	24.0	16.10	/	29.0	32.2	1.24
16B-1	25.40	15.88	17.02	8.28	35.60	37.2	21.00	/	60.0	72.8	2.84
20B-1	31.75	19.05	19.56	10.19	40.80	44.2	26.30	/	95.0	106.7	4.04
24B-1	38.10	25.40	25.40	14.63	53.30	58.0	33.30	/	160.0	178.0	7.14
28B-1	44.45	27.94	30.99	15.90	65.00	70.3	36.80	/	200.0	222.0	9.48
32B-1	50.80	29.21	30.99	17.81	65.20	71.0	42.00	/	250.0	227.5	10.19
40B-1	63.50	39.37	38.10	22.89	82.20	89.2	52.96	/	355.0	394.0	16.2
48B-1	76.20	48.26	45.72	29.24	99.10	107.00	63.80	/	560.0	621.6	25.52
56B-1	88.90	53.98	53.34	34.32	114.60	123.00	77.80	/	850.0	940.0	35.53
64B-1	101.60	63.50	60.96	39.40	130.30	140.00	89.67	/	1120.0	1240	45.77
72B-1	114.30	72.39	68.58	44.48	147.00	156.00	103.60	/	1400.0	1550	60.5

# BS Straight Side Plate Chain (continued)

## Technical Data Sheet

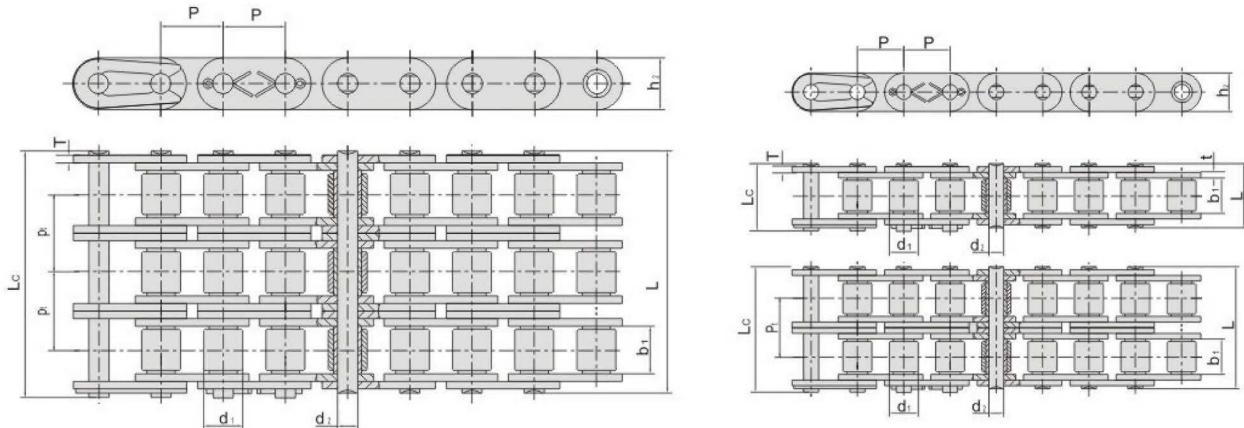

ISO 链号	节距 Pitch	滚子直径 Roller diameter	内节内宽 Width between inner plates	销轴直径 Pin diameter	销轴长度 Pin length		内链板高度 Inner plate depth	链板厚度 Plate thick- ness	排距 Transverse pitch	极限拉伸载荷 Ultimate tensile strength	平均拉伸载荷 Average tensile strength	每米长重 Weight per meter
					L	L <sub>c</sub>						
					max	max						
ISO Chain No.	P	d <sub>1</sub> max	b <sub>1</sub> min	d <sub>2</sub> max	L max	L <sub>c</sub> max	h <sub>2</sub> max	t/T	Pt	Q min	Q <sub>o</sub>	q
	mm	mm	mm	mm	mm	mm	mm	mm	mm	KN	KN	kg/m
C08B-1	12.70	8.51	7.75	4.45	16.7	18.0	11.8	1.60		18.0	19.5	0.79
C10B-1	15.875	10.16	9.65	5.08	19.6	21.0	14.7	1.70		22.4	27.5	1.06
C12B-1	19.05	12.07	11.68	5.72	22.5	24.0	16.0	1.85		29.0	32.2	1.19
C16B-1	25.40	15.88	17.02	8.28	36.0	37.2	21/24.0	4.15/3.1		60.0	72.8	2.91
C20B-1	31.75	19.05	19.56	10.19	41.1	44.7	26.4	4.5/3.5		95.0	106.7	4.19
C24B-1	38.10	25.40	25.40	14.63	53.3	58.0	33.2	6.0/5.0		160.0	178.0	7.47
C28B-1	44.45	27.94	30.99	15.90	65.0	70.3	36.9	7.5/6.4		200.0	222.0	9.90
C32B-1	50.80	29.21	30.99	17.81	66.0	71.0	42.1	7.0/6.4		250.0	277.5	10.45
C08B-2	12.70	8.51	7.75	4.45	31.0	32.1	11.8	1.60	13.92	32.0	38.7	1.45
C10B-2	15.875	10.16	9.65	5.08	36.2	37.5	14.7	1.70	16.59	44.5	57.8	2.00
C12B-2	19.05	12.07	11.68	5.72	42.0	43.6	16.0	1.85	19.46	57.8	66.1	2.62
C16B-2	25.40	15.88	17.02	8.28	68.0	69.1	21/24.0	4.15/3.1	31.88	106.0	133.0	6.10
C20B-2	31.75	19.05	19.56	10.19	77.8	81.5	26.4	4.5/3.5	36.45	170.0	211.2	8.23
C24B-2	38.10	25.40	25.40	14.63	101.7	106.2	33.2	6.0/5.0	48.36	280.0	319.2	14.77
C28B-2	44.45	27.94	30.99	15.90	124.6	129.1	36.9	7.5/6.4	59.56	360.0	406.8	19.82
C32B-2	50.80	29.21	30.99	17.81	124.6	129.6	42.1	7.0/6.4	58.55	450.0	508.5	20.94
C08B-3	12.70	8.51	7.75	4.45	44.9	46.1	11.8	1.60	13.92	47.5	57.8	2.10
C10B-3	15.875	10.16	9.65	5.08	52.8	54.1	14.7	1.70	16.59	66.7	84.5	2.87
C12B-3	19.05	12.07	11.68	5.72	61.5	63.2	16.0	1.85	19.46	86.7	101.8	3.89
C16B-3	25.40	15.88	17.02	8.28	99.8	102.9	21/24.0	4.15/3.1	31.88	160.0	203.7	9.12
C20B-3	31.75	19.05	19.56	10.19	114.2	117.9	26.4	4.5/3.5	36.45	250.08	290.0	11.34
C24B-3	38.10	25.40	25.40	14.63	150.1	154.6	33.2	6.0/5.0	48.36	425.0	493.0	22.10
C28B-3	44.45	27.94	30.99	15.90	184.2	188.7	36.9	7.5/6.4	59.56	530.0	609.5	29.64
C32B-3	50.80	29.21	30.99	17.81	183.2	188.2	42.1	7.0/6.4	58.55	670.0	770.5	31.27



# Maintenance-Free Roller Chain

## Technical Data Sheet

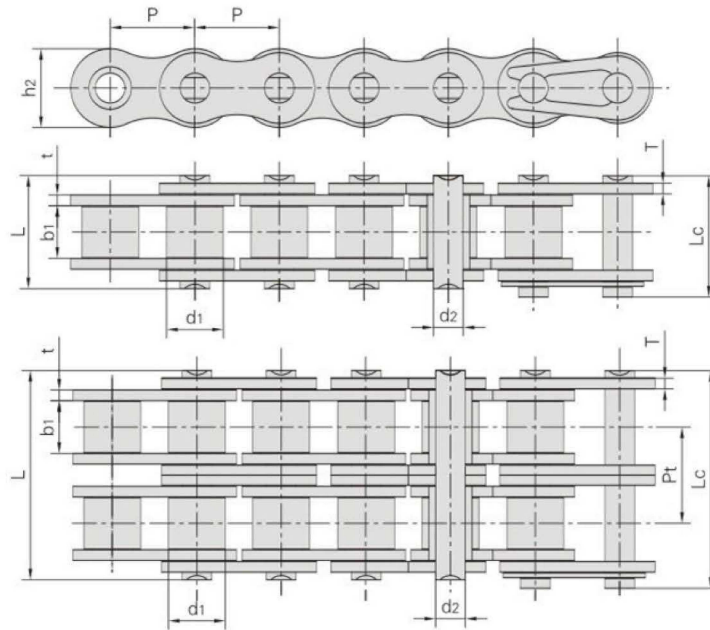

永利百合 链号 UNIBER Chain No.	节距 Pitch	滚子直径 Roller diameter	内节内宽 Width between inner plates	销轴直径 Pin diameter	销轴长度 Pin length		内链板高度 Inner plate depth	链板厚度 Plate thickness	排距 Transverse pitch	极限拉伸载荷 Ultimate tensile strength	每米长重 Weight per meter
	P	d1 max	b1 min	d2 max	L max	Lc max	h2 max	t/T max	Pt	Q min	q
	mm	mm	mm	mm	mm	mm	mm	mm	mm	KN	kg/m
08BSLR	12.700	8.51	7.75	4.45	16.7	18.1	11.80	1.6		18.0	0.69
08BSLRF1	12.700	8.51	7.75	4.45	17.3	18.7	11.80	1.6		18.0	0.72
10BSLR	15.875	10.16	9.65	5.08	19.6	21	14.70	1.7		22.4	0.93
10BSLRF1	15.875	10.16	9.65	5.08	19.9	21.6	14.70	1.7		22.4	0.97
12BSLR	19.050	12.07	11.68	5.72	22.5	24	16.00	1.85		29.0	1.15
12BSLRF1	19.050	12.07	11.68	5.72	22.9	24.7	16.00	1.85		29.0	1.19
16BSLR	25.400	15.88	17.02	8.28	35.6	37.2	21.00	4.15/3.1		60.0	2.71
16BSLRF1	25.400	15.88	17.02	8.28	36.7	39.7	21.00	4.15/3.1		60.0	2.73
40SLR	12.700	7.95	7.85	3.96	16.3	17.8	12.00	1.5		14.1	0.62
50SLR	15.875	10.16	9.40	5.08	20.2	22.2	15.09	2.03		22.0	1.02
60SLR	19.050	11.91	12.57	5.94	25.9	27.5	18.00	2.42		34.2	1.59
80SLR	25.400	15.88	15.75	7.92	32.8	34.1	24.00	3.25		56.7	2.60
08BSLR-2	12.700	8.51	7.75	4.45	30.6	32	11.80	1.6	13.92	32.0	1.34
10BSLR-2	15.875	10.16	9.65	5.08	36.2	37.6	14.70	1.7	16.59	44.5	1.84
12BSLR-2	19.050	12.07	11.68	5.72	41.1	43.5	16.00	1.85	19.46	57.8	2.46
16BSLR-2	25.400	15.88	17.02	8.28	67.5	69.1	21.00	4.15/3.1	31.88	106.0	5.45
40SLR-2	12.700	7.95	7.85	3.96	31.0	32.2	12.00	1.5	14.38	28.2	1.12
50SLR-2	15.875	10.16	9.40	5.08	39	40.3	15.09	2.03	18.11	44.4	2.00
60SLR-2	19.050	11.91	12.57	5.94	48.8	50.3	18.00	2.42	22.78	68.4	3.14
80SLR-2	25.400	15.88	15.75	7.92	61.9	64.2	24.00	3.25	29.29	113.4	5.32

# Contact Us Today

It's good to talk...

Let's come together in discussing & optimising your specific Chain Supply needs.



Howcroft Group Ltd, Unit 9, Brookfields Way, Manvers, Rotherham, S63 5DL



hello@howcroft.group



+44 (0)1709 878282

[www.howcroft.group](http://www.howcroft.group)

**HOWCROFT**  
group limited

**HOWCROFT**  
Industrial Supplies

chainSupply<sup>UK</sup>

ROZEM APPLE  
CLOTHING

